

USER MANUAL

SLD 30W ECO SOLAR LIGHT



Initial calibration and activation

1. Place the fitting solar panel side down on a level surface
2. Ensure the cable from the battery is connected securely
3. Using the remote control, press the button labeled "DEMO". The indicator light on the solar light head should flash three times, meaning the light has activated and will now begin its initial calibration.
4. The "DEMO" mode will illuminate the fitting for one minute then turn off. This is normal calibration setup. Do not use the remote control at this time.
5. After a full 5 minutes the fitting will have finished initial calibration and illuminate in its default mode.
6. Set your designed program from the remote
7. Leave the light operating and install. When the solar panel detects sunlight, it will turn off, this is normal operation. The fitting will illuminate as program at dusk. ■

Installing the SLD 30W ECO Solar Light

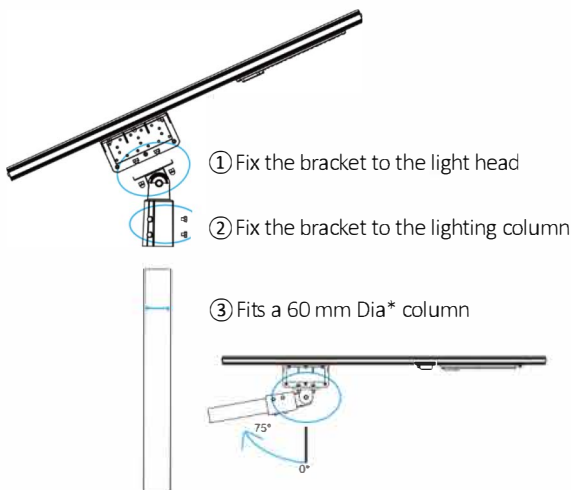

Battery Capacity and Remote Control Instructions

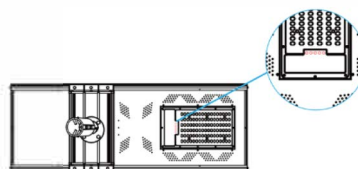

- 🔦 **DEMO:** Turns on for 1 minute for test use
- ⏻ **OFF:** Auto ON at dusk/OFF at dawn, Remote selected:
 - 🌙 100% output for 2hrs, 70% for 2hrs, 30% until dawn.
 - 🕒 100% output for 1hr, 70% for 2hrs, 40% for 3hrs.
 - 🌅 50% output for 1hr, 100% for 3 hrs, 30% until dawn.
 - 🌃 100% output for 1hr, 70% for 3hrs, PIR activated to 50% from 20% standby until dawn.